

YTE Suspension Installation & Maintenance

For Your Trailer Axle Suspension Needs Call York :

Head Office

Singapore

York Transport Equipment (Asia) Pte. Ltd.
No. 5 Tuas Avenue 6, Singapore 639295
Email : enquiry@yorktpt.com.sg
Tel : (65) 6861 0577 Fax : (65) 6861 4045

Hanger Installation and Welding (YTE 75, YTE 75/90 & YTE 90 Suspension)

First position the two front hangers on the frame, ensuring they are square to the frame and located in line longitudinally and transversely. All diagonal measurements and dimensions to be within 2mm maximum variation. Position the rest of the suspension hangers on the frame, see dimensional detail drawings for layouts, all spacings to be held to within 2mm of those shown.

Tack weld the hangers in position and recheck their position before final welding.

The material of the hanger is of cast steel BS3100-A2. All welding to be low hydrogen electrodes (such as Kobelco LB-52U) or equivalent M.I.G process. Weld all around the top of each hanger bracket - 10mm continuous fillet weld.

After installation of all hanger brackets, fit between the front hangers and all pairs of equaliser hangers either a pipe or channel cross bracing. Fully weld the ends of the cross bracing to their respective hangers. (See **Fig. A**)

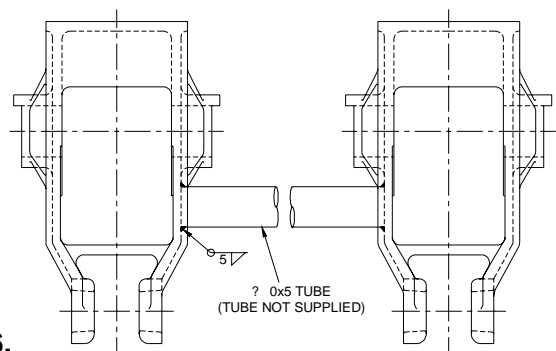

Fig. A

Axle Seat Installation and Welding

Choose Spring Seat Center:	See Page 3.
Choose Brake Chamber Position:	See Pages 4 - 6.
YTE 75 Suspension	Page 4
YTE 75/90 Suspension	Page 5
YTE 90 Suspension	Page 6
Axle Seat Installation and Welding:	See Pages 7 - 9.
YTE 75 Suspension	Page 7
YTE 75/90 Suspension	Page 8
YTE 90 Suspension	Page 9

Position axle seats at correct centres. (Must match suspension hanger centres.) The centre bolt holes of axle seats must be at the top of axle for overslung suspensions and the bottom centre for underslung suspensions. Axle seats must be flat and parallel with each other. Tack weld the axle seats in position and recheck their positioning before final welding.

The material used for the spring seat is cast steel BS3100-A2. Weld the axle seats to the axle using low hydrogen electrodes (such as Kobelco LB-52) or equivalent M.I.G process and 8mm fillet weld. It should not exceed more than 30mm for 6" round axle or 40mm for 6" square axle above or below the axle centre line.

Axle Bottom Plate Installation and welding: **See Page 10.**
(for YTE 90 Suspension Only)

Spring Assembly

Assemble the springs onto the axles, ensuring that:

The hook end of the spring is to be fitted to the rear of the axle on all axle positions.

Tighten U-bolt nuts evenly to a torque of: - M22 (for 8 leaf spring) **500/540 Nm.**

- M24 (for 10 leaf spring) **640/680 Nm.**

YTE 75, 75/90 & 90 Suspension Spring Center Calculation

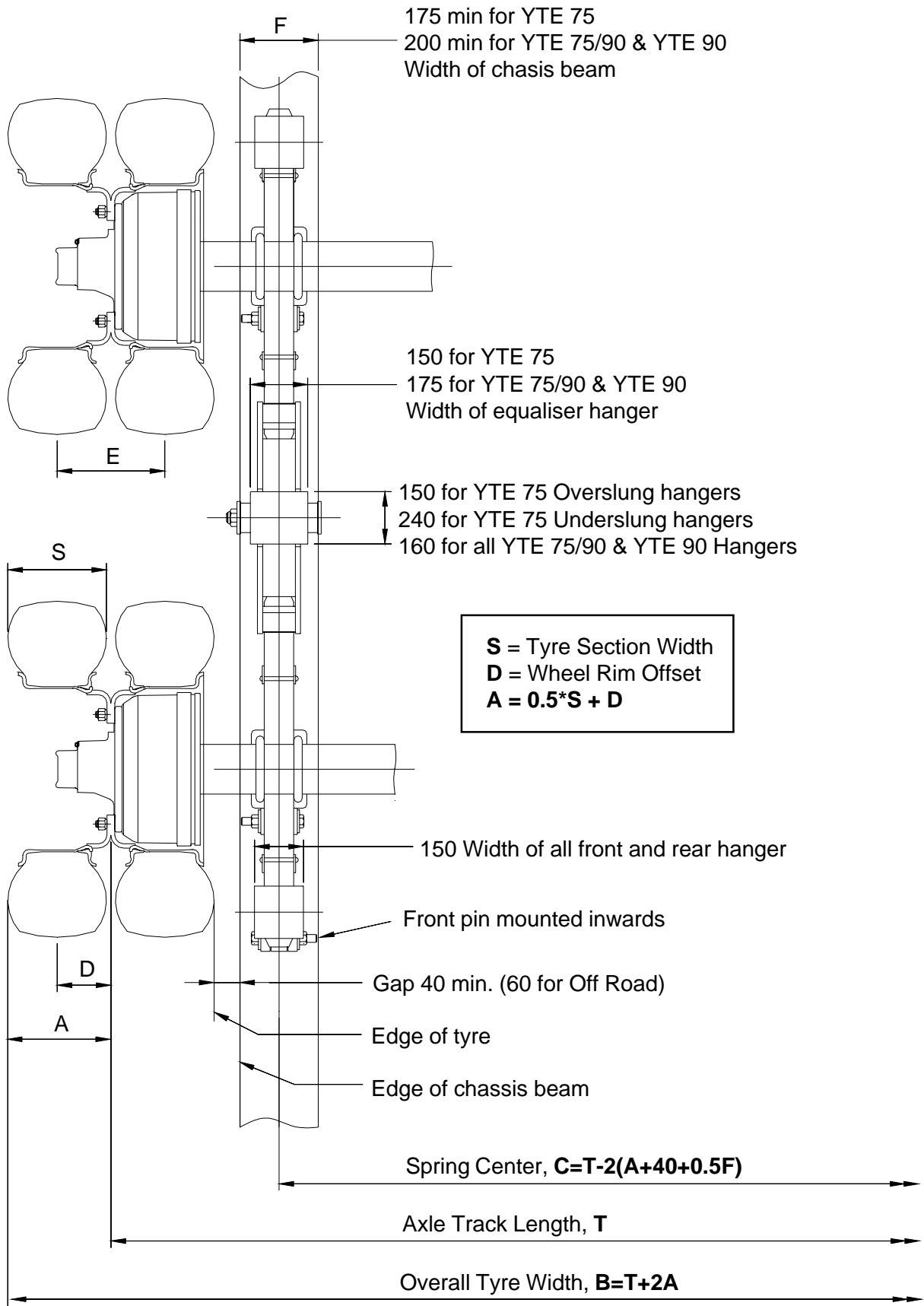

YTE 75 Suspension Camshaft & Brake Chamber Positions

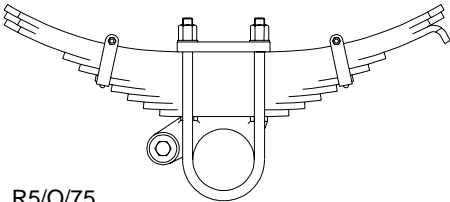
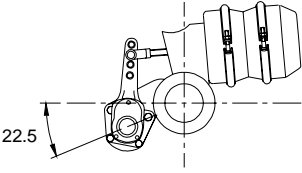
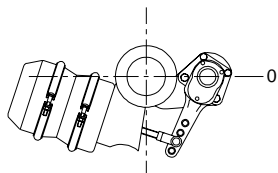
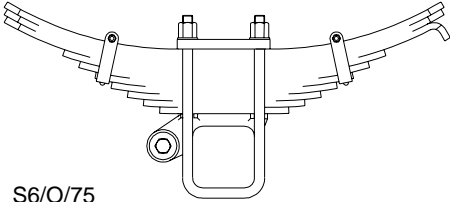
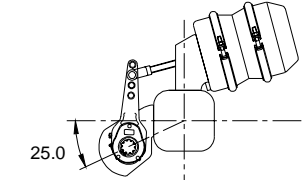
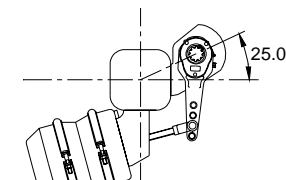
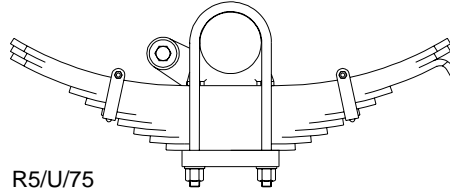
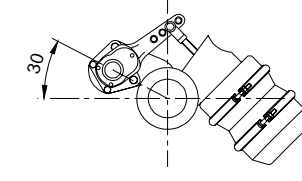
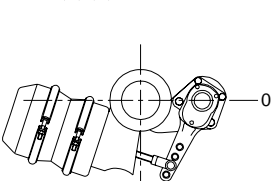
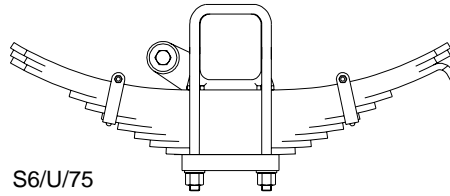
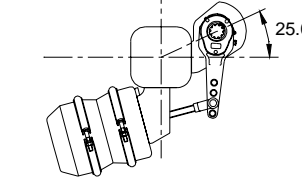
	SPRING INSTALLATION		BRAKE CHAMBER POSITION	
	STANDARD		STANDARD	OPTIONAL (Note 1)
OVERSLUNG 5" ROUND AXLE BEAM	 R5/O/75		 CAM LOCATION - R5-1	 CAM LOCATION - R5-2
OVERSLUNG 6" SQUARE AXLE BEAM	 S6/O/75		 CAM LOCATION - S6-1	 CAM LOCATION - S6-2
UNDERSLUNG 5" ROUND AXLE BEAM	 R5/U/75		<p style="text-align: center;">FRONT OF TRAILER ←</p>  CAM LOCATION - R5-3	 CAM LOCATION - R5-2
UNDERSLUNG 6" SQUARE AXLE BEAM	 S6/U/75		 CAM LOCATION - S6-2	

Note 1: Optional brake chamber position is only for approval application on good highway without overloading (≤ 11 Ton).

YTE 75/90 Suspension Camshaft & Brake Chamber Positions

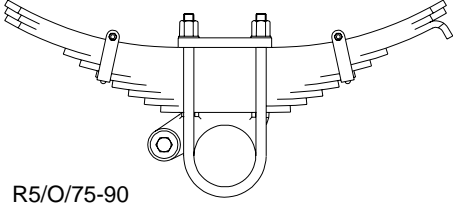
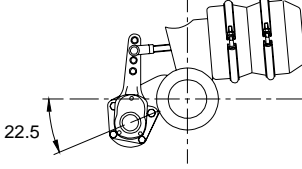
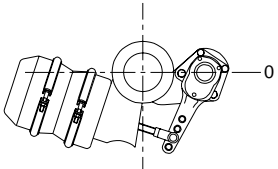
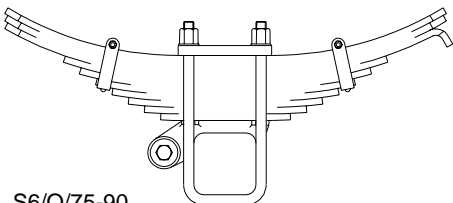
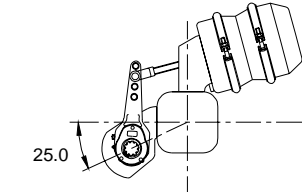
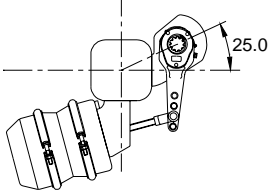
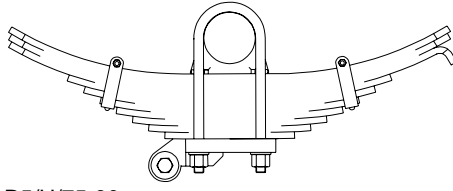
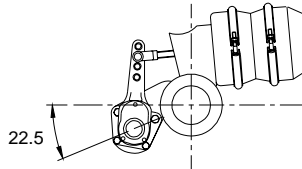
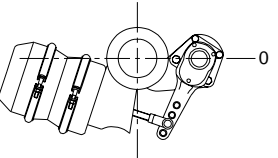
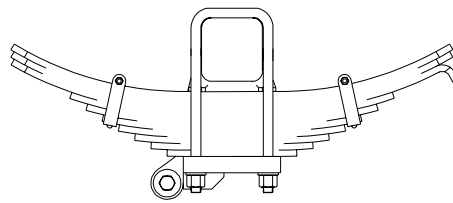
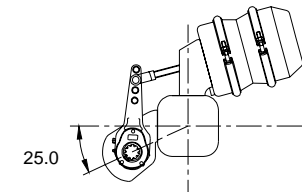
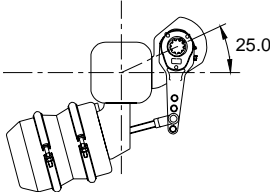
	SPRING INSTALLATION	BRAKE CHAMBER POSITION	
	STANDARD	STANDARD	OPTIONAL (Note 1)
OVERSLUNG 5" ROUND AXLE BEAM	 <p>R5/O/75-90</p>	 <p>22.5</p> <p>CAM LOCATION - R5-1</p>	 <p>0</p> <p>CAM LOCATION - R5-2</p>
OVERSLUNG 6" SQUARE AXLE BEAM	 <p>S6/O/75-90</p>	 <p>25.0</p> <p>CAM LOCATION - S6-1</p>	 <p>25.0</p> <p>CAM LOCATION - S6-2</p>
UNDERSLUNG 5" ROUND AXLE BEAM	 <p>R5/U/75-90</p>	<p style="text-align: center;">FRONT OF TRAILER ←</p>  <p>22.5</p> <p>CAM LOCATION - R5-1</p>	 <p>0</p> <p>CAM LOCATION - R5-2</p>
UNDERSLUNG 6" SQUARE AXLE BEAM	 <p>S6/U/75-90</p>	 <p>25.0</p> <p>CAM LOCATION - S6-1</p>	 <p>25.0</p> <p>CAM LOCATION - S6-2</p>

Note 1: Optional brake chamber position is only for approval application on good highway without overloading (≤ 11 Ton).

YTE 90 Suspension Camshaft & Brake Chamber Positions

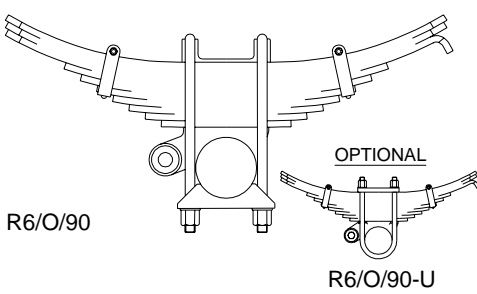
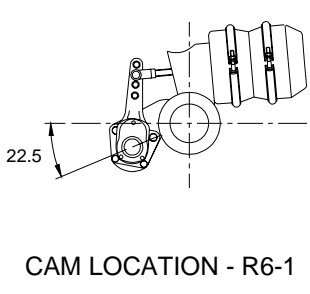
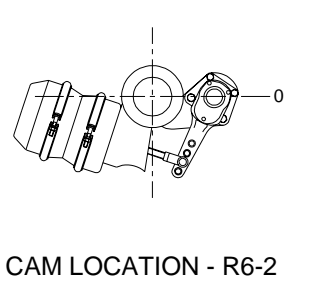
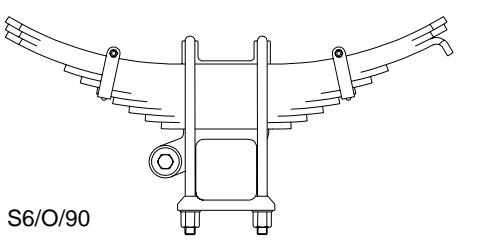
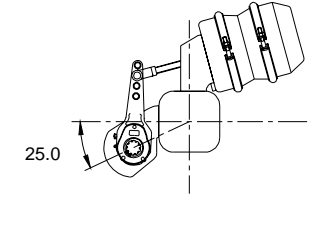
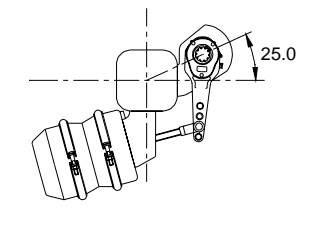
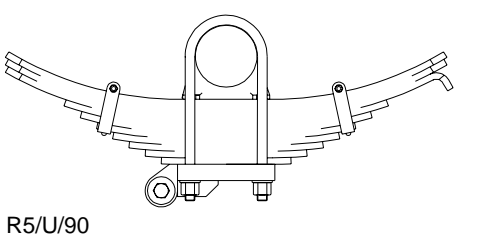
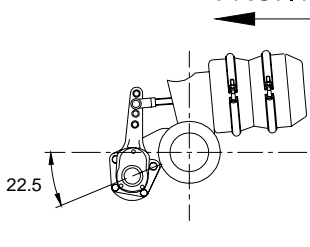
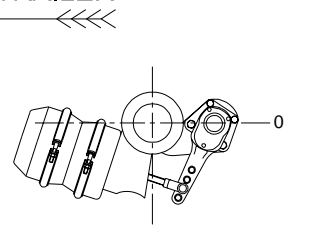
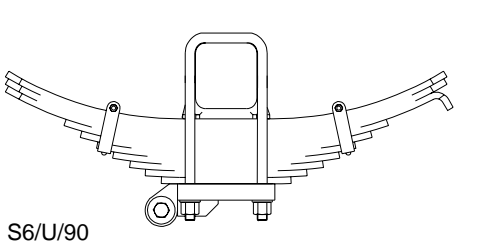
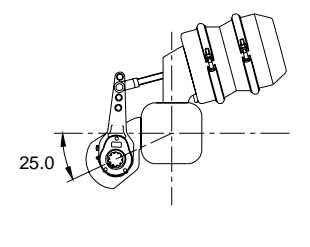
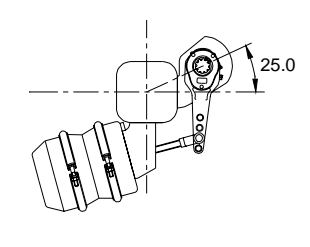
	SPRING INSTALLATION		BRAKE CHAMBER POSITION	
	STANDARD		STANDARD	OPTIONAL (Note 1)
OVERSLUNG 6" ROUND AXLE BEAM	 <p>R6/O/90</p> <p>R6/O/90-U</p>		 <p>22.5</p> <p>CAM LOCATION - R6-1</p>	 <p>CAM LOCATION - R6-2</p>
OVERSLUNG 6" SQUARE AXLE BEAM	 <p>S6/O/90</p>		 <p>25.0</p> <p>CAM LOCATION - S6-1</p>	 <p>25.0</p> <p>CAM LOCATION - S6-2</p>
UNDERSLUNG 6" ROUND AXLE BEAM	 <p>R5/U/90</p>		<p style="text-align: center;">FRONT OF TRAILER ←</p>  <p>22.5</p> <p>CAM LOCATION - R6-1</p>	 <p>CAM LOCATION - R6-2</p>
UNDERSLUNG 6" SQUARE AXLE BEAM	 <p>S6/U/90</p>		 <p>25.0</p> <p>CAM LOCATION - S6-1</p>	 <p>25.0</p> <p>CAM LOCATION - S6-2</p>

Note 1: Optional brake chamber position is only for approval application on good highway without overloading (≤ 11 Ton).

YTE 75 Suspension Spring Seat Welding

5" Round Beam Overslung

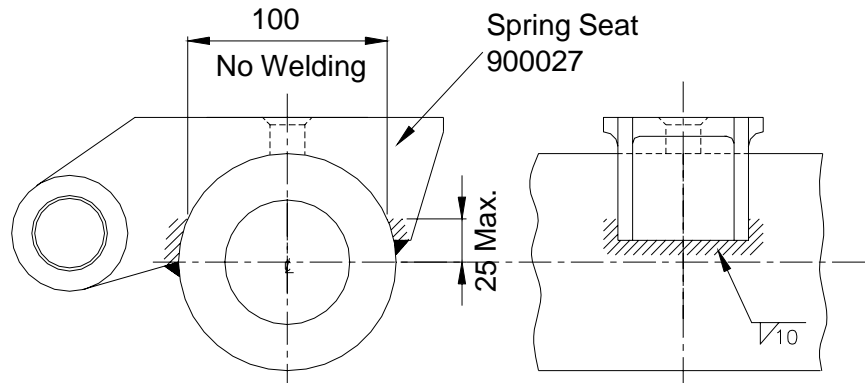

5" Round Beam Underslung

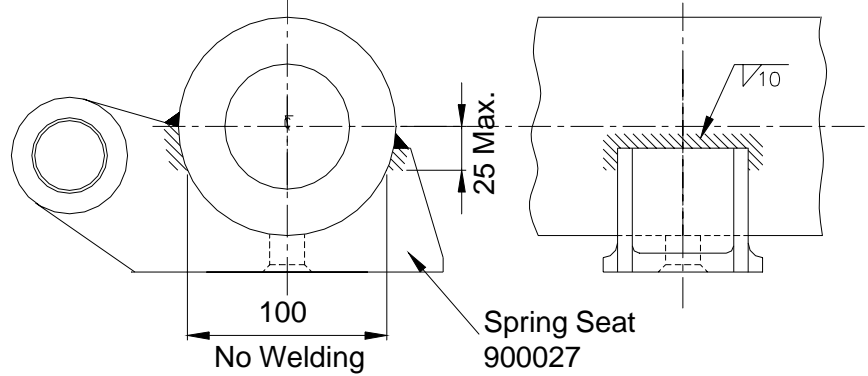

6" Square Beam Overslung

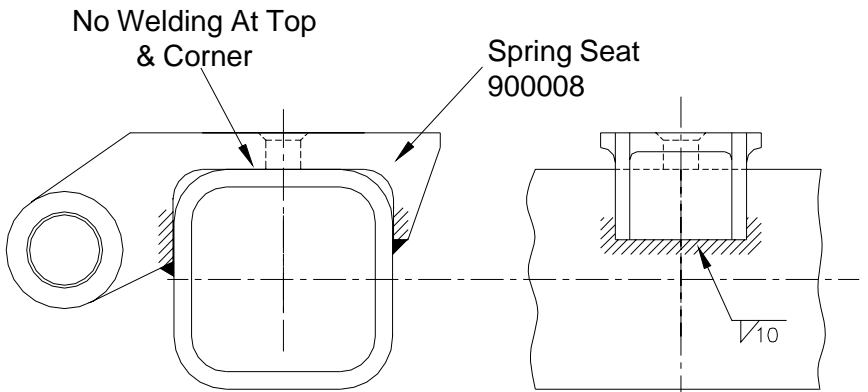

6" Square Beam Underslung

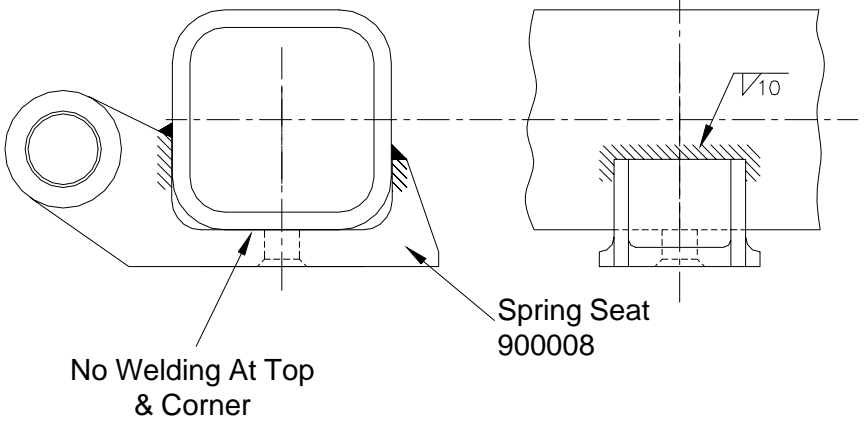

YTE 75/90 Suspension Spring Seat Welding

5" Round Beam Overslung

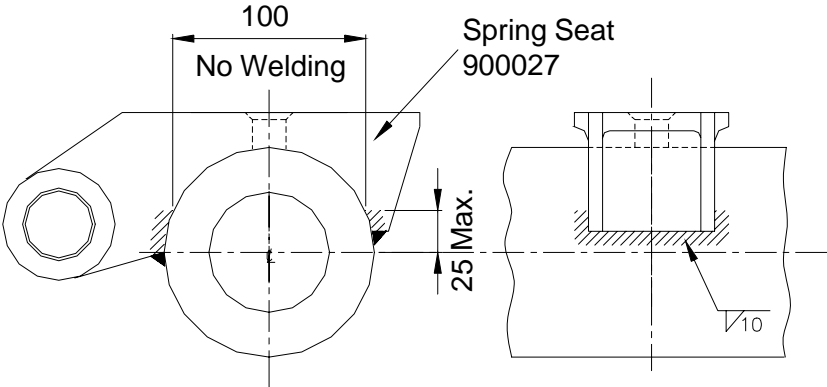

5" Round Beam Underslung

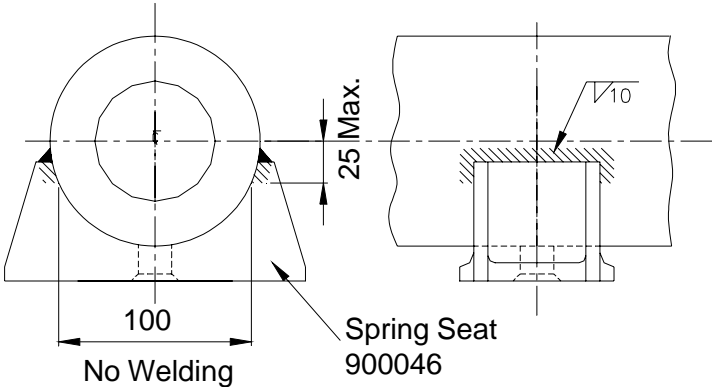

6" Square Beam Overslung

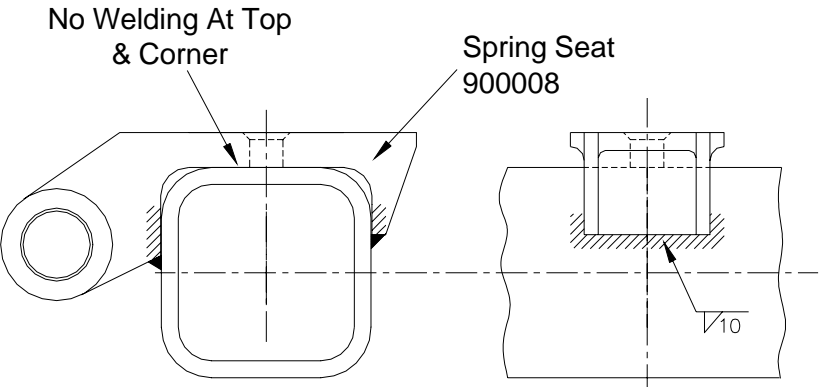

6" Square Beam Underslung

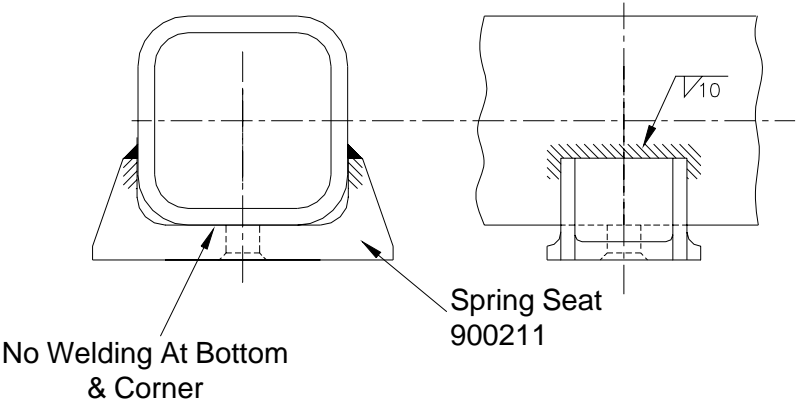

YTE 90 Suspension Spring Seat Welding

6" Round Beam Overslung

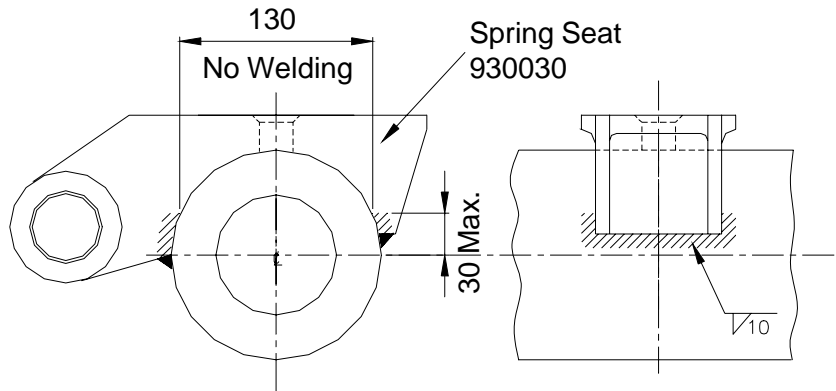

6" Round Beam Underslung

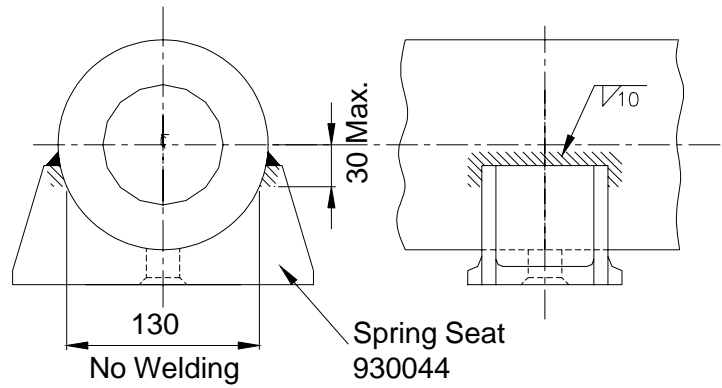

6" Square Beam Overslung

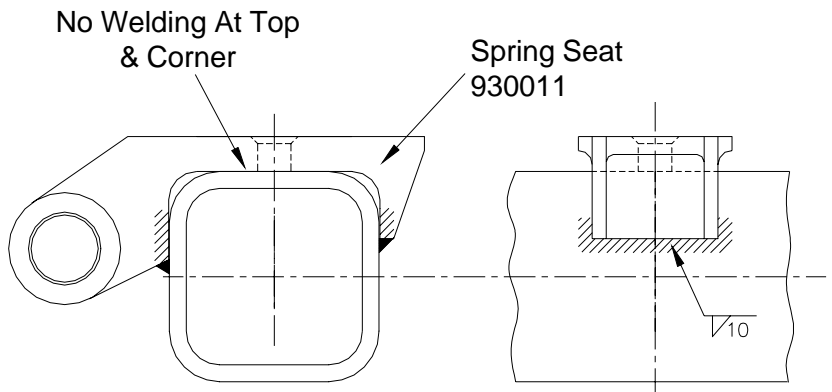

6" Square Beam Underslung

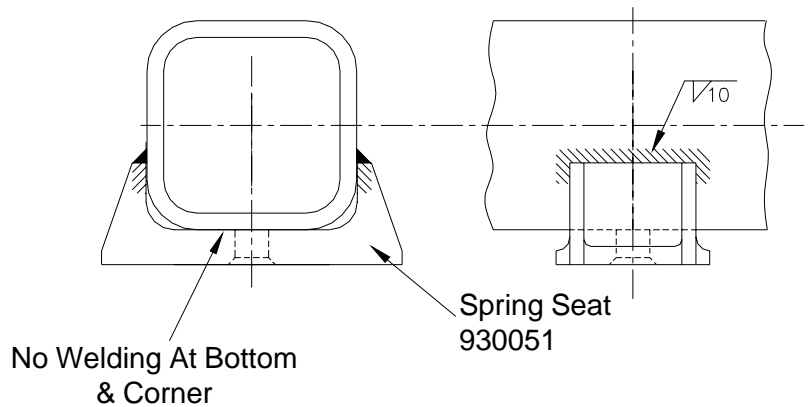

**Only For YTE 90 Overslung With U-Bolt Top To Bottom
Welding of Bottom Clamp Plate**

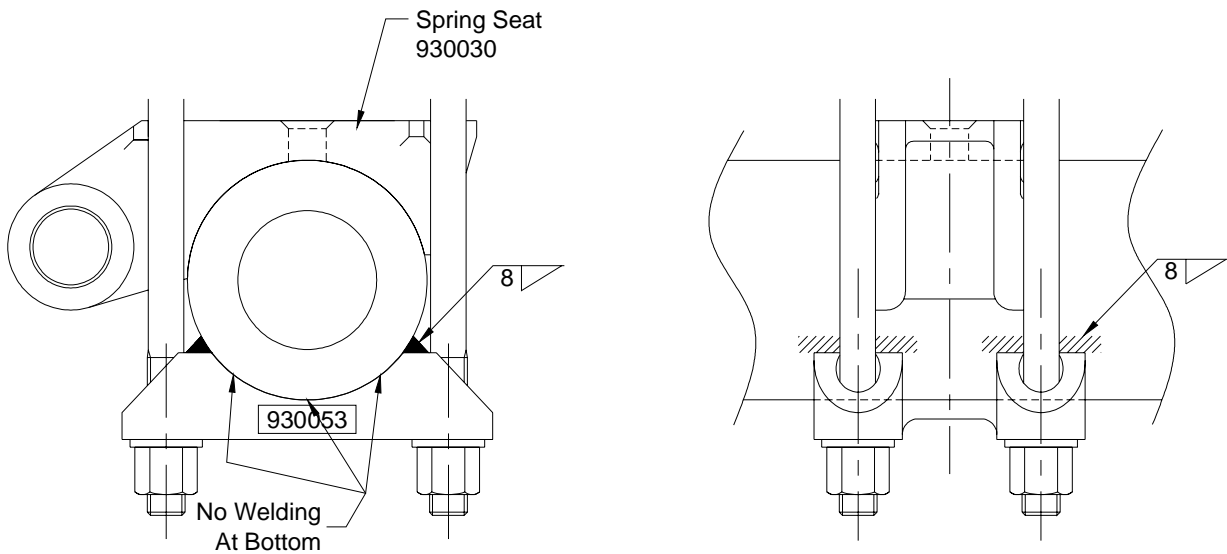

6" Round Axle Beam

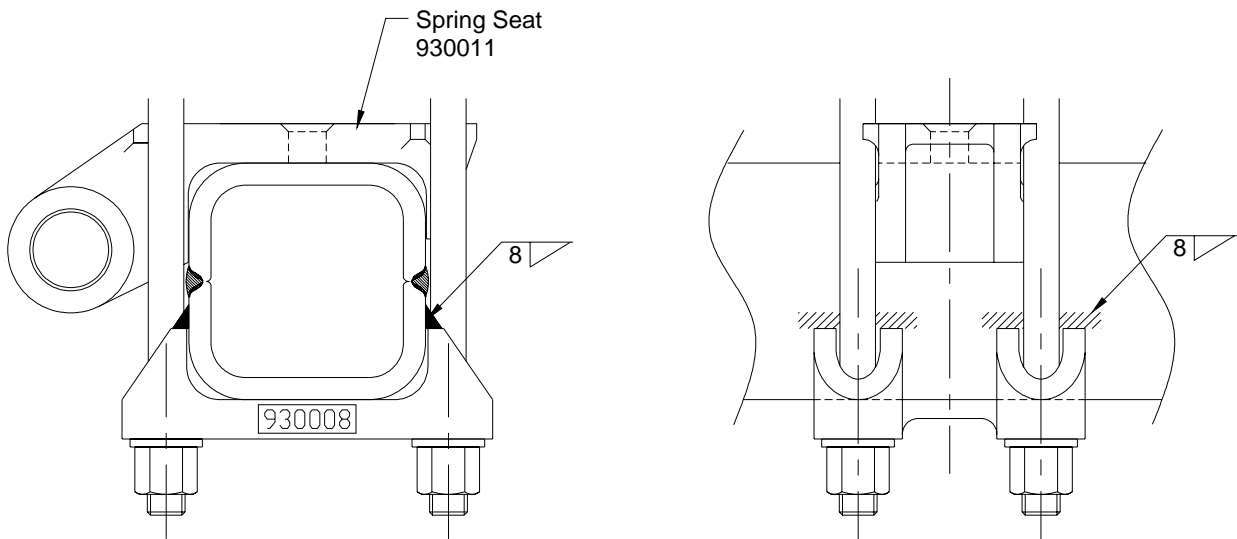

6" Square Axle Beam

Welding Procedure:

1. Position the bottom clamp plate at correct location right below the spring seat. Make sure the bottom clamp seat firmly against axle beam
2. Fillet weld 8 mm bottom clamp plate.
Make Sure No Welding At Bottom of Axle Beam.
3. Assemble U-bolts and tighten all the nuts to 640-680 Nm.

Axle Assembly

Fit the axle, spring assembly into position and connect to the front and equaliser hangers through the torque arms, making sure the spring hooked ends fit into the equalisers. Insert spring retaining bolts into the equalisers and hangers.

Assemble the adjustable torque arms to the same length as the corresponding fixed torque arms. Fit the fixed torque arms on the kerb (near) side and the adjustable torque arms on the road (off) side of the trailer.

- On tandem and tri-axle suspensions the centre and rear torque arms will be longer than those on the front axle.
- On all underslung suspensions the adjustable torque arms must be installed with the clamp bolts to the top or as shown on the assembly drawings.

Torque Arm Bush Installation

Fit the end of the torque arm in the suspension bracket and insert the bushes from each side, fit torque arm pin, flat washers and self locking nut, ensuring that the torque arms are central in the suspension bracket.

Tighten torque arm pin self locking nuts to:

- M24	150/200 Nm. (Rubber bushes)
- M24	240/270 Nm. (Poly bushes)

The Way Of Bush Installation:

The rubber bush is the standard one for most highway suspension. When the rubber bushes are properly tightened to 150/200 Nm, the bush material protrusion will be less than **2 mm**. (See **Fig. B**).

The poly (polyamide) bush is designed for heavy duty operation (rough road, heavy duty and intensive operation). After initial proper tightening, the bush material protrusion should not be more than **7 mm** each side (See **Fig.C**).

Both rubber and poly taper bush need to be compressed for maximum service life. In practices, the bush should be tightened in sequence:

- Lubricate all tapered rubber or poly bushes or use a light oil or detergent or rubber grease) before fitting into the suspension bracket.
- Manually (low speed, not very fast speed when using a torque gun) as far as possible. If operator use torque gun (speed setting), the bush material protrusion will be bigger and bushes will not be compressed.

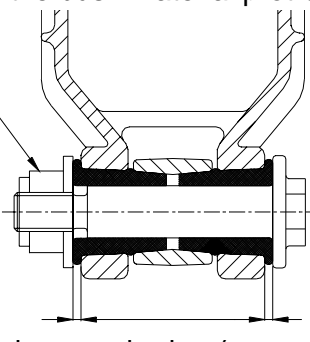

for maximum service life, the bush should be tightened in sequence:
 1) Lubricate all tapered rubber or poly bushes or use a light oil or detergent or rubber grease) before fitting into the suspension bracket.
 2) Manually (low speed, not very fast speed when using a torque gun) as far as possible. If operator use torque gun (speed setting), the bush material protrusion will be bigger and bushes will not be compressed.

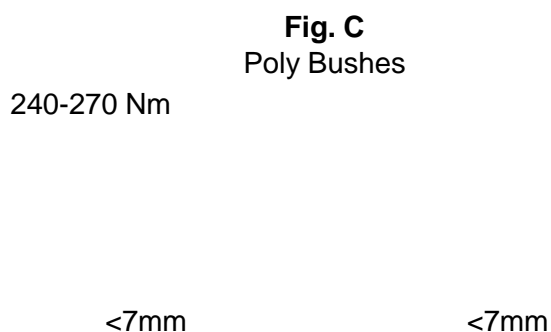
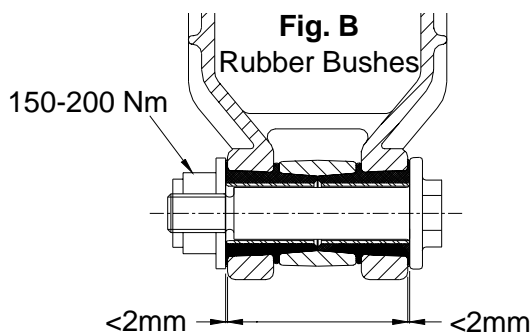

Axle Alignment and Adjustment

Measure from the centre of the kingpin to the centre of each end of the front axle and adjust as necessary with the adjustable torque arm screws until the dimensions are equal.

Alignment of the rear axle (axles) is then made by checking the distance between the centre of the front axle and rear axle (axles) at both sides of the trailer. Adjust as necessary with the adjustable torque arm screws until the dimensions are equal.

Note :

Alignment can also be achieved with an optical device or laser system designed specifically for this purpose.

$$\begin{aligned} A &= B \pm 2 \text{ mm} \\ C &= D \pm 1 \text{ mm} \\ E &= F \pm 1 \text{ mm} \end{aligned}$$

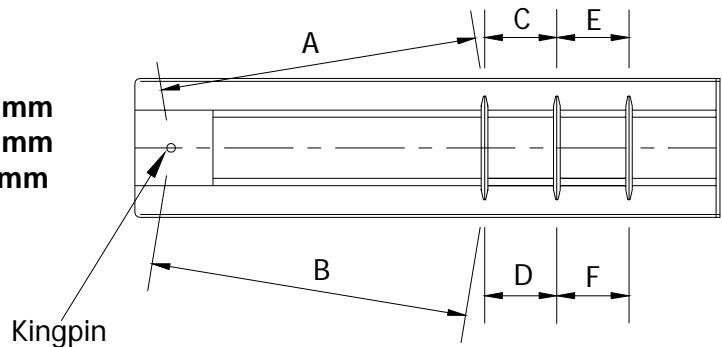

Tighten the torque arm clamp bolts to a torque of : **95 Nm (M12)**.

Be careful! Torque wrench must be used here. Over-tightening will damage the thread of clamping bolt. For each adjustable torque arm end, 2 clamping bolts should be tightened alternatively for at least 4 times so that both clamping bolts achieve 95 Nm. (see Page 16)

Adjustment of Equaliser Position (See next Page 13)

When considering the suspension and axle to be fitted to a new trailer always take into account the angle of slope as shown in **Fig. D**. If this angle of slope is greater than that shown below for each type of suspension in the laden condition then the equaliser will have excessive tilt (see **Fig. E**). This tilt will reduce the equaliser movement causing the equaliser to strike hanger or chassis frame under uneven (rough) road conditions.

This can be overcome by welding a 25 mm thick packer to the spring seats (see **Fig. F**). The same result can be achieved by welding spacers between the main frame and the top of suspension hanger brackets (see **Fig. G**).

If the angle of slope is greatly in excess of the following slopes, a spring seat or packer of greater height of 25mm will be required to combat the equaliser tilt.

Tandem suspension: One in fifty (25mm higher on front axle)

Tri-axle suspension: One in one hundred (25 mm higher on front axle, 12 mm higher on center axle)

Note: No higher spring seats or packers are necessary if the bottom of the trailer main beam and the ground are parallel.

Tri-axle suspension: Experience has shown that the correct installation of tri-axle suspension is more critical than that of tandem suspensions. When the trailer angle of slope in the laden condition is greater than the angle of slope specified then reduced equaliser travel will cause uneven axle loading (possibly overloading some axles).

Overloading on some axles can cause excessive tyre wear or even failure, particularly when cornering. Therefore, it is imperative when installing tri-axle suspension that attention is paid to the laden trailers' angle of slope. If the slope is greater than one in two hundred, then spring seat of correct height or packers of correct thickness must be fitted to both the front axle and center axles (The highest spring seat or packers being fitted to the front axle).

Trailer Slope vs. Equaliser Position

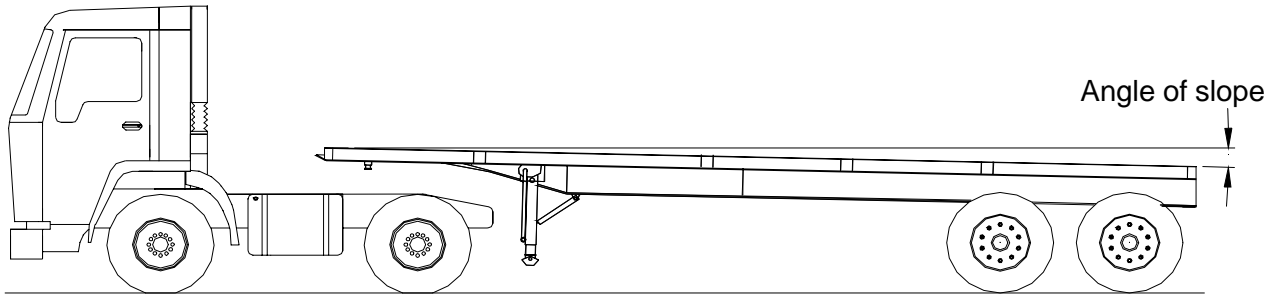

Fig. D

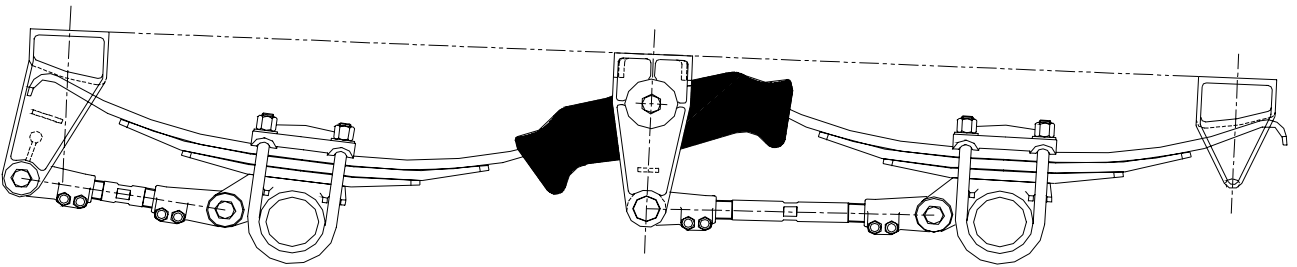

Fig. E

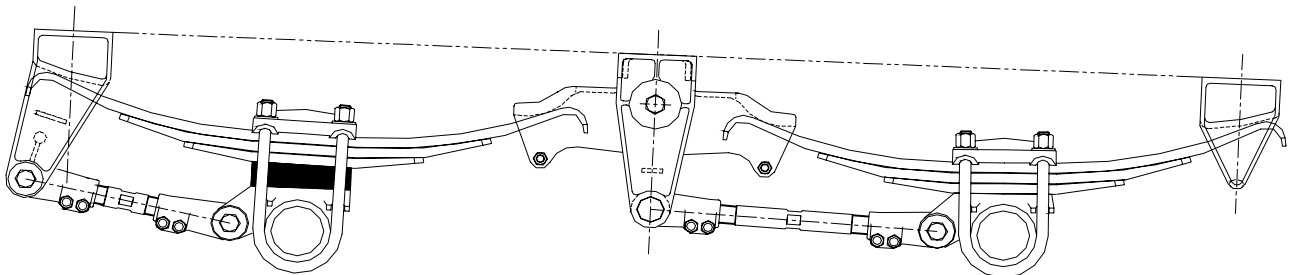

Fig. F

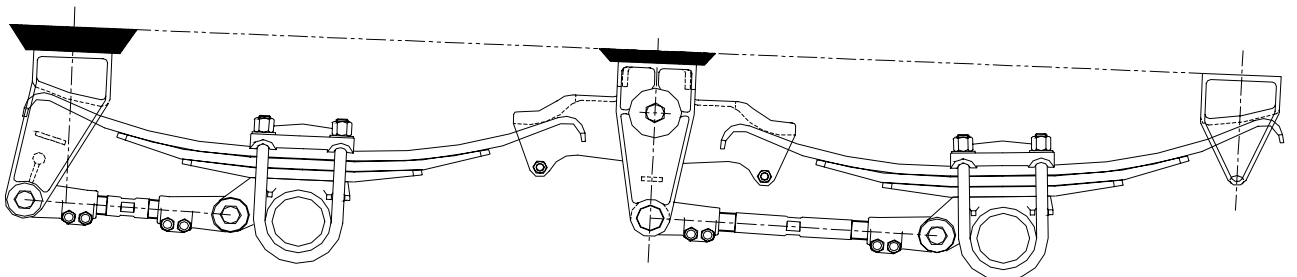

Fig. G

Adjustment of Equaliser Position, Continued.

The height of spring seat or packer can only be determined by considering each installation individually after determining the fifth wheel height (laden), wheel base, tyre size, the trailer beam design, suspension height (laden) etc.

When the suspension has been matched to the designed laden fifth wheel height, the recommended variation should be within 38mm for wheel base and 50mm for the length of kingpin to center of suspension.

Equaliser Bump Stops (1540 Spacing on YTE 75/90 & YTE 90 Suspension Only)

For YTE 75/90 - 1540 axle spacing design, bump stops must be fitted at either end of all equalisers as drawings below. These bump stops are used for preventing damage or premature failure of hanger and equaliser when the equalisers rotate to their maximum position. This extreme position of the equalisers can occur (locked within the equaliser hanger) due to operations on very rough road conditions and incorrect installation of suspension on trailer frames where trailer frame slope is not taken into account (see pages 2 & 3). The extra load applied to the equaliser hanger and equaliser, in this condition causes damage and possibly failure of the castings.

Please take note that the stops are welded to trailer frame (main beam). The bump stops are not supplied as part of the suspension kit.

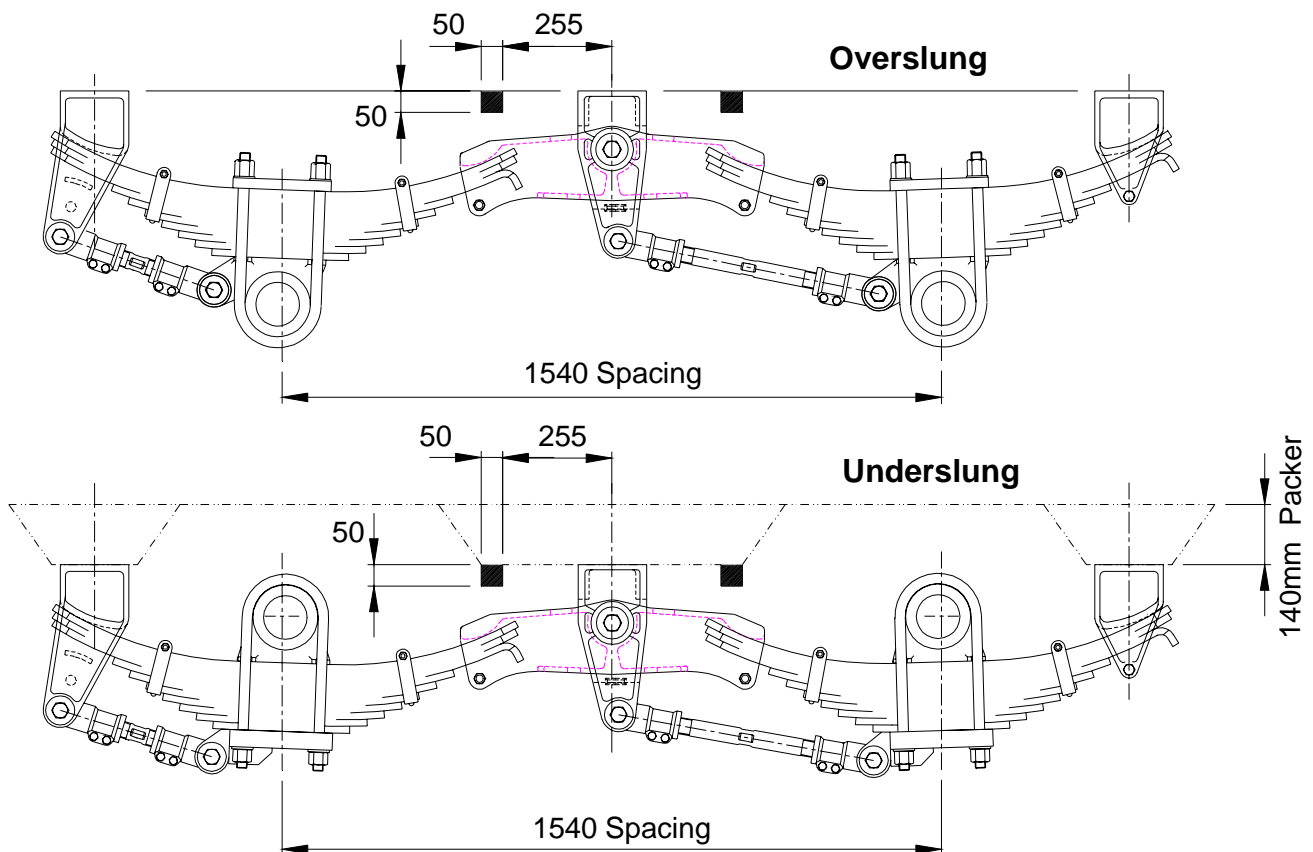

Final Inspection

A visual inspection of the suspension after installation and assembly should be carried out to ensure that all components are correctly located and seated, as incorrect location or misalignment of the components will greatly reduce the service life of the suspension.

Servicing Intervals (On Highway).

First Service - 500 km.

- Check all torque settings and re-torque.

Every 5,000 km or every 3 weeks.

- Check all torque settings (Especially U-bolt and torque arm pin nut).
- Grease equaliser shafts (straight bush design only) using an EP2 grease or equivalent.

It is recommended that the vehicle is lifted (jacked up) so that the load is removed from the equalisers when greasing these points. For vehicles operating in severe and dusty conditions it is recommended that the bushing is greased daily.

Every 50,000 km or every 6 months.

- Check and lubricate as for 5,000 km service.
- Check the torque arm bushes, equaliser shaft bushes for wear or deterioration and replace as necessary.
- Check the leaf springs for wear, cracks or corrosion and replace as necessary.
- Inspect the remainder of the suspension for wear or deterioration and replace any suspect parts as necessary.
- Check tyre wear and adjust the axle alignment as necessary.

Axle alignment must be checked when ever severe kerbing, accident damage or the torque arm bushes have been replaced during servicing.

Servicing Intervals (Off Road Intensive Operation).

First Service (or after parts changing) 500 km or 1 week.

- Check all torque settings and re-torque (Especially U-bolt and torque arm pin nut).

Daily.

- Daily greasing of the equaliser bushings can be done by service staff or an automatic lubricating machine.

It is recommended that the suspension equaliser bushings (straight design only) are lubricated daily.

To lubricate the equaliser bushings the load should be removed from the suspension by lifting up (jacking) the unit.

Weekly.

- Check all torque settings (Especially U-bolt and torque arm pin nut) with torque wrench.

Every 15,000 km or Monthly.

- Check all torque settings and lubricate as for daily and weekly service.
- Check the torque arm bushes, equaliser shaft bushes for wear, replace as necessary.
- Check the leaf springs for wear, cracks or corrosion and replace as necessary.
- Inspect the remainder of the suspension for wear or deterioration and replace any suspect parts as necessary.
- Check tyre wear and adjust axle alignment as necessary.

Axle alignment must be checked whenever severe kerbing, accident damage or the torque arm bushes have been replaced during servicing.

YTE 75 Suspension

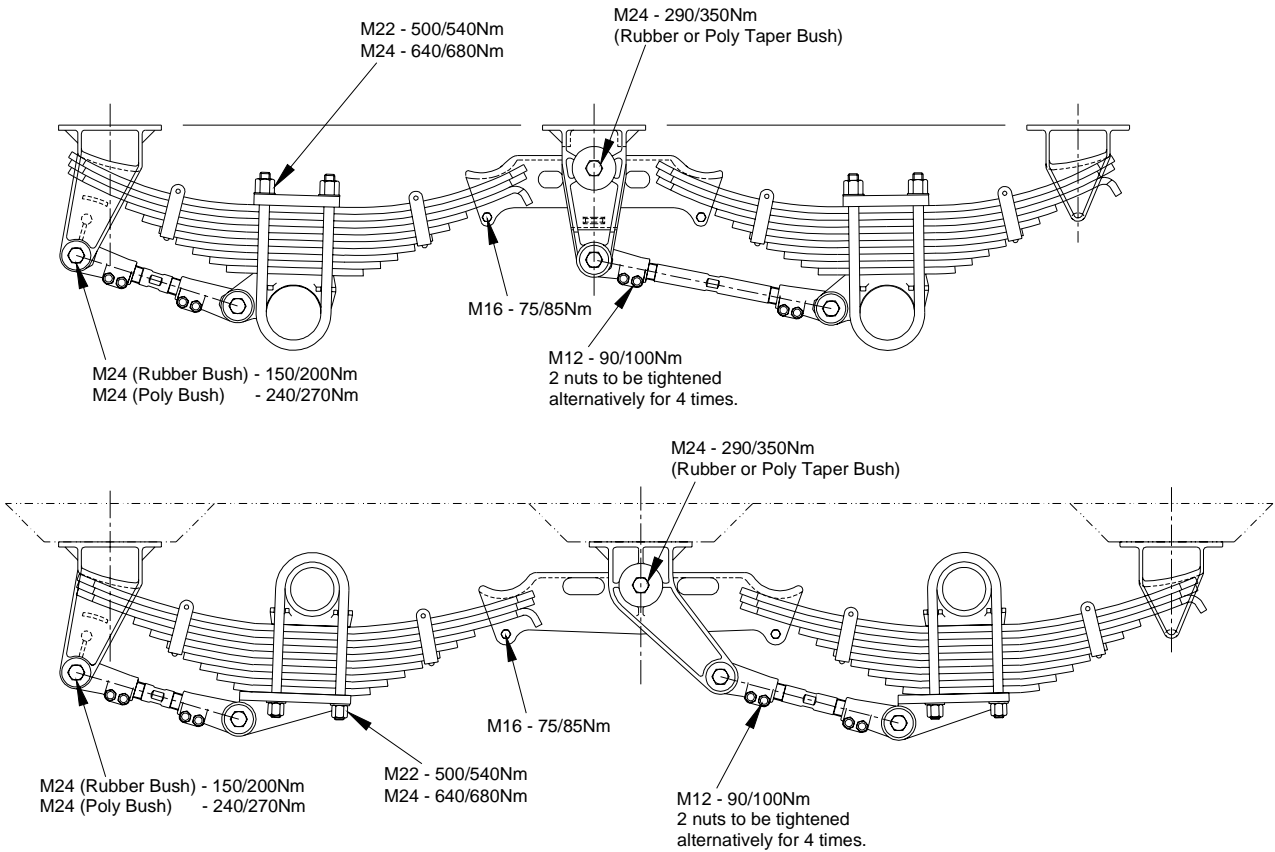

YTE 75/90 & 90 Suspension

